



Proceeding
INTERNATIONAL
CONFERENCE ON
SUSTAINABLE
ENGINEERING AND
TECHNOLOGY

"Engineering and Technology
Innovation for Sustainability"



Published by:
UST-PRESS



Rectorate Office
UST Main Building
Jalan Batikan UH-III/1048 Yogyakarta
55167

Yogyakarta, June 7th, 2022 (Virtual)
ISBN: 978-602-6258-30-4

PUBLISHED BY:
UST-PRESS
UNIVERSITAS SARJANAWIYATA TAMANSISWA

PROCEEDING

**INTERNATIONAL CONFERENCE ON
SUSTAINABLE ENGINEERING AND TECHNOLOGY**

**Engineering and Technology Innovation for
Sustainability**

Yogyakarta, June 7th, 2022 (Virtual)

Published by:

**UST PRESS
UNIVERSITAS SARJANAWIYATA TAMANSISWA**

THE PROCEEDING OF INTERNATIONAL CONFERENCE ON SUSTAINABLE ENGINEERING AND TECHNOLOGY

Engineering and Technology Innovation for Sustainability

ADVISORY BOARD

1. Prof. Drs. H. Pardimin, M.Pd., Ph.D
2. Dra. Hj. Trisharsiwi, M.Pd
3. Drs. Widodo Budhi, M.Si

STEERING COMMITTEE:

1. Dr. Imam Ghozali, M.Sc
2. Yuyun Yulia, M.Pd., Ph.D

ORGANIZING COMMITTEE:

Conference chair	:	Zainul Faizien Haza, Ph.D
Event coordinator	:	V. Reza Bayu Kurniawan, S.T., M.Sc
Secretary	:	Dewi Sulistyorini, S.T., M.Eng
Treasury	:	Iswanto Apri Nugroho, S.T
Seminar & Proceeding	:	M. Afif Shulhan, S.T., M.Eng Emmy Nurhayati, S.T., M.Eng
Design and IT	:	Yoga Martha Susila, S.Kom

EDITORS:

Dr. Ir. Iskandar Yasin, S.T., M.T., CIPM., IPM
Ir. Widarto Sutrisno, S.T., M.T
Lilik Hendro W., S.T., M.Eng
Julia Kurniasih, S.T., M.Kom
Ir. Syamsul Ma'arif, S.T., M.Eng

REVIEWERS:

Assoc. Prof. Ts. Dr. Mohd Hisbany Mohd Hashim
Mega Novita, S.Si., M.Si., M.Nat.Sc., Ph.D
M.S. Hendriyawan Achmad, S.T., M.Eng., Ph.D
Dr. Triyanna Widiyaningtyas, S.T., M.T.
Dr. Eng. Luky Handoko, S.T., M.Eng
Yanuar Haryanto, S.T., M.Eng., Ph.D
Syam Widiyanto, S.T., M.Eng
Dian Eksana Wibawa, S.T., M.Eng
Raja Putra Jaya, S.T., M.Eng
Dian Pranata Putra Ambali, S.T., M.Eng

Copyright © 2022 Universitas Sarjanawiyata Tamansiswa
ISBN 978-602-6258-30-4

PUBLISHED BY:

UST-Press

UST Main Building. Jalan Batikan UH-III/1043 Yogyakarta 55167

PREFACE

On behalf of the organizing committee of the International Conference on Sustainable Engineering and Technology, we are very pleased that this first international conference held by the faculty of engineering Universitas Sarjanawiyata Tamansiswa was successful. This conference aims to firstly explore, to recognize, and to discuss the trends, challenges, and opportunities about engineering and technology innovation for sustainability, and secondly, to provide the publication output in the form of ISBN proceeding as a medium to disseminate research results.

The concept of sustainability which has recently been developing significantly in various studies provides a huge number of practical and theoretical implications. It is obvious that the current technological development as well as innovation creation should bring the benefits to various sectors by taking into account sustainability pillars. In other words, innovations on engineering and technology are not only aimed at profit or economic interests, but also in today's modern world, concerns on environmental and social aspects are also getting more serious attention. Further, this situation is certainly demanding challenges that the contribution bringing economic benefits should also consider minimal negative impacts on environment. Simultaneously, the social positive impacts may also be increased. By considering these three pillars, the sustainable development can be achieved. Therefore, apart from the challenges, more opportunities will also be obtained in order to ensure the sustainability-oriented innovations.

Finally, we are very glad that this forum provides a space to collaborate and discuss the modern world's issues. In this opportunity, we also express our appreciation to the keynote speakers, presenters, and participants who proactively share their thoughts and ideas in this event. We hope that this event will be even better in the coming year, and thus, the continuous improvement is certainly necessary.

**Dean & the Organizing
Committee**

TABLE OF CONTENTS

COVER PAGE	i
THE COMMITTEE STRUCTURE	ii
PREFACE	iii
TABLE OF CONTENTS	iv

ARTICLES AND AUTHORS	PAGE
Section: CIVIL ENGINEERING (CODE: CE)	
Forensic Analysis of Soil Improvement Methods in River Delta Area for Railway Mode Angga Darmawan	1-11
Load and Capacity Evaluation of 32 Meters Prestressed Concrete I-Girder Muhammad Iswahyudi, M Afif Shulhan, Dewi Sulistyorini, Ziyah Fariz Karomah	12-16
Pavement Condition Index (PCI) Method for Road Damage Analysis Febriani Datu Sarira, Lilik Hendro Widaryanto, Ahmad Mashadi	17-23
Absorption of Cadmium (Cd) Metal Particulates on Tanjung (Mimusops Elengi) and Bungur (Lagerstroemia Speciosa) Leaves S. Sunarsih¹, A. D Warisaura, G. Andaka	24-30
The Compressive Strength of Fly Ash and Stone Dush in Concrete Dewi Sulistyoini, Dimas Langga Chandra Galuh, Mafazi Azizan	31-35
Comparative Study of Unit Price Analysis of Wages, Materials and Equipment on Excurement Work and Head Works Between SNI Method and Field Cornelius Agatho Gellu	36-39
Analysis of Road Damage Using the Bina Marga Method (Case Study of The Balirejo Road Section, Special Region of Yogyakarta) Germaldus F, Zainul Faizien Hasa, Dimas Langga	40-46
Analysis of Road Surface Damage Level on Road Surface Campurejo-Wates, Temanggung Regency using The SDI (Surface Distress Index) Method Wachid Nur Ihsan, Widarto Sutrisno, Dimas Langga	47-55

ARTICLES AND AUTHORS	PAGE
Unit Price Comparison Analysis Study on Job Couple of Stone with Mortar Asamalia, Widarto Sutrisno, Zainul Faizen	56-65
Analysis of Bearing Capacity and Degradation of Borepile Foundation on Kretek Bridge Construction Project Unun Muhammad Nurrohman, Zainul Faizen Haza, Dimas Langga Chandra	66-71
Analysis of Safety Management System Implementation and Occupational Health (SMK3) In Development Projects Red White Hospital Novia Ciptaningrum, Iskandar Yasin, Lilik Hendro Widaryanto	72-76
Internal Water Treatment Plant Effectiveness Improving the Quality of Clean Water Treatment Metta Dhamayanti, Dewi Sulistyorini, Lilik Hendro Widaryanto	77-85
Evaluation of The Performance of The Jalan Structure Due to Pasar Activities Market Prawirotaman – Jalan Parangtritis Dede Rachmat Dirja, Ahmad Mashadi, Widarto	86-90
Analysis Of Accident Problems on The Yogya Road Segment Winosari, Gunungkidul Regency Diki loyal, Dewi Sulistyorini, Afif Shulhan	91-101
Factor Analysis of Accident on Parakan Road – Kledung Temanggung Regency (Case Study of Accident Areas in Temanggung Regency) Richa Ulya Nugraha, Agus Priyatno, Dimas Langga Chandra	102-116
Yogyakarta-Magelang Road Accident Analysis Sleman District Abdul Nurroman Wahyu A, Dewi Sulistyorini, Widarto Sutrisno	117-123
Comparisional Analysis of RAB (Cost Budget Plan) Metode Konvensional with Metode BIM (Building Information Modelling) (Studi Kasus Gedung Kuliah Tiga Lantai di Yogyakarta) Anton Ainurrofiq	124-133
Damage Value of Wave Breaker Protection Coating That was Placed by Organized and Raised Due to Wave Attack Ida Bagus Agung	134-140
Application of Occupational Safety and Health (K3) on The Project ASANKA Building Yogyakarta Development Joseph Jaga Nuhan, Dewi Sulistyorini, Angga Darmawan	141-148

ARTICLES AND AUTHORS	PAGE
The Stability of Banjar Traditional House “Bubungan Tinggi” Roof Truss Structure Miftahul Iman, Muhammad Yusuf Amir, Aminullah, Fitriansyah, Dewi Sulistyorini	149-158
The Flood between the Balance of Natural Systems and the Challenges of The Future Ahmad Mashadi	159-162
Sediment Deposit of Merapi Mount Eruption Adi Sutarto, Hanindya Artati, Iskandar Yasin, Zainul Faizin Haza, Widarto Sutrisno, Reja Putra Jaya	163-172
Damage Value of Wave Breaker Protection Coating That was Placed by Organized and Raised Due to Wave Attack Ida Bagus Agung	173-179
Strength and Strength of Lightweight Steel Reinforced Concrete Beam Iskandar Yasin, Lilik Hendro Widaryanto, Tori Pebrianto, Irenius Posong, Kamaludin	180-194
A Critical Literature Review on the Factors Causing Delays, Failures and Abandonments of Construction Infrastructure Projects Abdulhaqq Onoruoyiza Muhammed, Henry Anda Yakubu, Mercy Enotse Aboh, Adam Abubakar, Abdulsamad Adinoyi Muhammed	195-204

Section: INDUSTRIAL ENGINEERING (CODE: IE)

Work Accident Analysis at PT. Sinergi Perkebunan Nusantara Using Analytic Hierarchy Process Method (AHP) Dicky Wirandi Siswoyo, Kartinasari Ayuhikmatin Sekarjati	1-8
A Modernized Moth Flame Optimization Algorithm for Higher Dimensional Problems Saroj Kumar Sahoo1, Apu Kumar Saha	9-20
Design and Fabrication of Automatic Metal Plate Cutting Machine Rochmad Winarso, Rianto Wibowo, Puput I. Qur’aini, Teteg Wahyu Pamungkas	21-27
Analysis of Raw Material Inventory Control Using Economic Order Quantity (EOQ) for Furniture Manufacturing Company in Indonesia Catur Indri Cahyani, Argaditia Mawadati	28-33

ARTICLES AND AUTHORS	PAGE
Design Modelling Test for R80's aircraft Flight Deck with Human Digital Ergonomic Factors (HDEF) Anantia Prakasa	34-41
Proposed Quality Improvement Using Statistical Process Control (SPC) Method on Picking Process at JD.ID Warehouse FMCG Marunda Klarette Vivian Gloria Patty	42-48
Quality Improvement to Reduce Defective Rate of Bread Products Using Taguchi Method in UMKM Kembar Pastry Siti Puja Oktaria, Elly Wuryaningtyas Yunitasari, Dyah Ari Susanti	49-56
Application of Simulation for Cinema Queue Policy in the COVID-19 Era Dutho Suh Utomo , Masrul Indrayana , Retno Widiastuti	57-62
The Fire Trucks Line Modelling for Fires Mitigation in Dense Settlement Population Using Agent Based Model Simulation Approached Aprilla Warlisia Sandana	63-70
Garuda Indonesia Experience: A New Concept of Airline Service M. Mujiya Ulkhaq, Deshtyan Erlangga Adi, Jessika Ulina, Excel Verlieson Wijaya	71-75
Mathematical Analysis of Earth Air Heat Exchanger (EAHE) for Storage system Niraj R. Shingala and Dr. Chetankumar M. Patel	76-91
Inventory Control of Raw Material of Sawdust for The Production of Wood Pellets with Supply Chain Management Approach at PT Multi Energi Biomassa Imron Bondan Sadewa, Emmy Nurhayati, Kusmendar	92-98
Reverse Logistics for Medical Waste During the Covid-19 Pandemic: A Literature Review Yasmin Mauliddina	99-102
Warehouse Relay Layout Analysis Using Flow Process Chart and Dedicated Storage in CV Master Multi Jaya Valentino Ibanez, Agus Hindarto Wibowo	103-112
Usefulness Assessment of Powder Seasoning Packing Machine Based on the Overall Effectiveness Equipment Approach Nina Aini Mahbubah, Abdul Muid, Indra Rizaldi	113-118

ARTICLES AND AUTHORS	PAGE
Natural Ester Oil a Sustainable Alternative Insulation Oil to Mineral Oil for Power Transformer Industries and Electric Power System Amit Kumar	119-125
Identification of Export-Import Activities for MSMEs in Yogyakarta Through the Airport Using the House of Risk Dita Trianingrum, Atik Febriani	126-132
Scheduling Time and Project Costs Using the Critical Path Method (CPM) And the Evolution and Review Technique (PERT) Program on The Dust Collector Machine at Pt. The Glorious Element of Suryamasinka (Elgisa) Eka Putra Pebrianto, Elly Wuryaningtyas Yunitasari, Dyah Ari Susanti	133-142
Effectiveness Analysis of Pelletizer Machine Using Overall Resource Effectiveness (ORE) And Failure Mode and Effects Analysis (FMEA) Methods at Pt Multi Energi Biomassa Maria Nona Erlin, Augustinus Eko Susetyo, Syamsul Ma'arif	143-154
Lean Manufacturing Approach to Minimize Waste Production Using Value Stream Mapping Emmy Nurhayati	155-159
Student Portfolios Rescoring in an Indonesian Private University Based on a Fuzzy MCDM V. Reza Bayu Kurniawan, Fransiska Hernina Puspitasari	160-164
Green Supply Chain Management in Research Trend: Bibliometric Analysis Study Kusmendar, Dyah Ari Susanti, Bimo Sunarfri Hantono, Atik Febriani, Nada Iman Muvidah	165-171
Reduction of Bottleneck in the Jacket Production Process in the Sewing Department using Line Balancing Method Silvia Sri Oktarini, Ismianti Ismianti	172-178

Section: INFORMATICS AND INFORMATION SYSTEM (CODE: IF)

Grouping of General Hospitals Based on Specialist Doctors in the Special Region of Yogyakarta with the K-Means Clustering and Visualization on the Dashboard Tableau Erma Shofi Utami, Mercynanda Yuliany Alang, Rokhana Dwi Bkti, Edhy Sutanta	1-8
---	------------

ARTICLES AND AUTHORS	PAGE
Design a Smart Trash Using Fuzzy Logic Algorithm Muchamad Malik, Adi Prasetyo	9-17
A Review on A Greener Approach to Information Technology: Green Cloud Computing Ashish Kumbhare, Naveen Kumar Vaishnav, Kiran Midiyam, G. Dileep Naidu	18-22
Assessing the Impact of the Internet of Things Integration on the wellbeing of People in Office spaces, Nigeria: A Review Aboh Mercy Enotse, Abdulhaqq Onoruoyiza Muhammed, Saheed Olarewaju Yusuf, Femi Ayooluwa Aribisala, Segun Moses Ayodele and Jonathan Oluwapelumi Mobayo	23-27
Machine Learning for Identification of Learning Modalities Julia Kurniasih, Agung Budhi Wibowo	28-32
Code Creator Application Design to Create CRUD Module on Codeigniter Framework I Wayan Candra Winetra, Edhy Sutanta, I Wayan Julianta Pradnyana	33-40
Implementation of Inverse Kinematics Method for Self-Moving on Hexapod Robot Syamsul Ma'arif, Dyah Ari Susanti, Muchamad Malik	41-51
Methodologies of Artificial Intelligence in Power System Seemant Tiwari	52-56

Application of Simulation for Cinema Queue Policy in the COVID-19 Era

Dutho Suh Utomo^{1*}, Masrul Indrayana², Retno Widiastuti³

¹*Industrial Engineering, Universitas Mulawarman, Indonesia*

²*Industrial Engineering, Universitas Widy Mataram, Indonesia*

³*Industrial Engineering, Universitas Sarjanawiyata Tamansiswa, Indonesia*

*Corresponding author: Email: dutho@ft.unmul.ac.id

ABSTRACT

In the COVID-19 era, in a situation where the number of COVID-19 sufferers has decreased, there was a policy that allowed opening a business with one condition being to maintain a distance from human queues, including cinema ticket queues. Simulation is a method for comparing policies by analyzing the results of their implementation. Costs can be reduced by implementing simulations because policy testing is done by executing the designed model without implementing it directly. Therefore, the purpose of this study analyzed cinema queues in the COVID-19 era by comparing the policies of the previously designed queuing system. To get an effective queuing policy, the analysis was carried out by comparing the queues of various policies by considering the distance between the queues. This study developed a queuing policy that reduced the number of queues. The results obtained can be used to recommend the cinema on how to design a queuing system to reduce queues while maintaining distance settings.

Keywords: Simulation, COVID-19, Queue, Policy

1. INTRODUCTION

In the COVID-19 era, there were rules for maintaining distance among people, this also applied to queues which require that there was a distance between people who were queuing. This caused limit the queue capacity at a facility where there was a queue. A change in queuing policy will affect other attributes such as the length of the queue and the number of people served. In order to optimize these changes, an analysis is needed to know the impact of changes in queuing policies. Simulation can handle this, because simulation is a technique that can run a model and find out the impact of a scenario. simulation may be necessary because experimenting with real-life systems is risky and costly [1]. Before running the simulation, a model design that resembles the real world must be made, and then proposed changes to get the optimal model. Previous research has proven that the application of simulation by changing the scenario reduced the number of queues and increase the number of outputs [2].

Research on simulation applications has been carried out by several previous researchers. Alban et al (2020) applied simulation related to ICU capacity during COVID-19 [3]. Meanwhile, there was also a study applying applications related to mass vaccination during COVID-19 [4]. Another study used discrete event simulations to evaluate shift plans during the COVID-19 period [5]. In addition, there was also the discrete event simulation model application at the university related to the COVID-19 testing [6]. There was also a study regarding queue analysis on the COVID-19 condition [7]. In addition, there were also some researches that discussed the problem of queuing with simulation [8][9][10][11][12][13]. Based on the above background then the purposes of this study were developing a queuing simulation model in conditions of queuing restrictions due to COVID-19 and making changes to the scenario (number of cashier) to see the impact of employees, queues and consumers.

2. METHODS

In this study, a queuing system model was created, then adjustments were made to the proposal by limiting the queue. The analysis used in this study was an analysis with a discrete event system with the help of simulation software. The queuing system initially used a single queue and a single server for each cashier. Discrete event simulation was used in this study. In discrete-event simulations, system changes are represented only at points in time or the system is modeled as a series of events in time when the state change occurs [14].

A proposed model was developed that describes a queuing system at the cashier which consisted of several cashiers with queues that were limited due to distance and queue capacity. Queue restrictions based on distance and capacity set. The input data for the simulation consisted of time between arrival and service time. Before running the simulation, it is necessary to run setup. In the run setup, there are replication parameters settings such as replication length [15]. In this study, the simulation was run for 2 hours and then compared for each scenario of adding cashiers

3. RESULTS AND DISCUSSION

The results of the initial queuing system modeling consisted of 3 components, namely arrival, server and exit from the queuing system. The queue was in front of each server (cashier) with a predetermined number of cashiers. Meanwhile, the entity flow began from visitors who entered to the cinema with the time between arrival at the component and then went to the cashier queue for buying tickets, visitors went to the quietest queue and will be served immediately if there was none line up. Then after being served by the server (cashier) according to the service time with the distribution expression $4 + 7.84 * \text{BETA} (1.19, 1.75)$. After being served, visitors exited the queue system. An overview of the initial design of the queuing system could be seen in Figure 1.

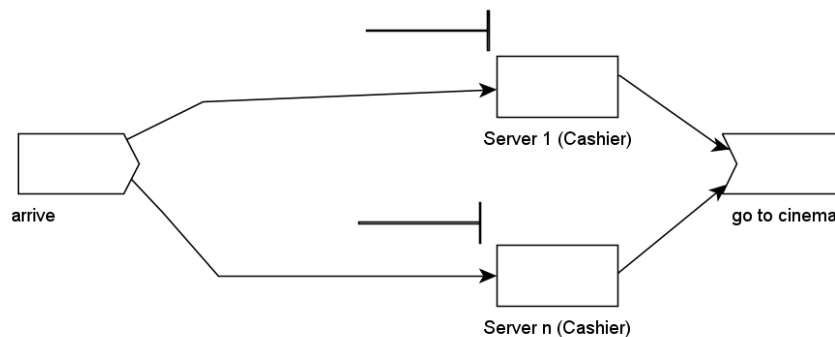

Figure 1. Initial design of the queuing system

The change in the design of the proposed model compared to the initial model was that there was a limit to the number of queues caused by the limitations of queuing distance and queuing capacity. The description of the proposed model (figure 2) consisted of several components, namely arrival, the decision to enter or not, server (cashier), and exit of a queuing system.

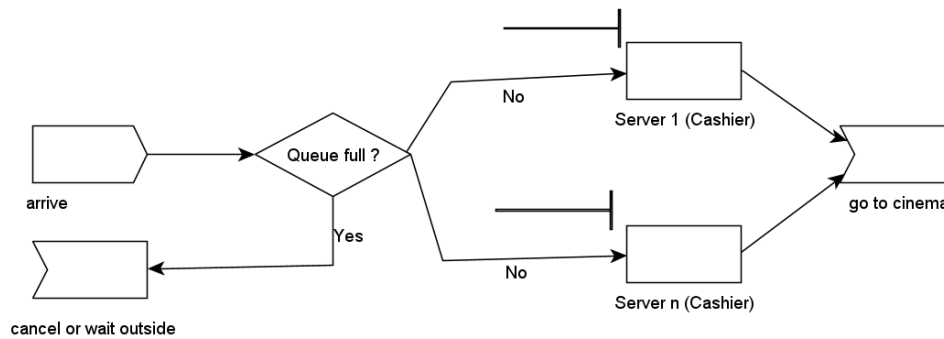

Figure 2. The proposed design of the queuing system

The proposed alternative scenario in this study was to change the number of cashiers and then analyzed the impact on the queue, cashier utility, and the number of people watching and waiting outside or canceling to watch due to queue restrictions. The output of the queuing system with the cashier is 1 (table 1), the number of waiting was 19 people. Meanwhile, the cashier's utilization was 1. This indicated that during 2 hours of work the cashier had no idle time at all with 18 people being served. While 49 people did not enter because the queue was full. From these results, it was necessary to add a cashier to get the optimal parameter size results.

Table 1. Results of simulation with 1 server

Description	Value
Number of waiting (Average) Total	19
Average of Waiting Time (minutes)	46.79
Utilization of cashier 1	1
Total Number Seized (Chasier 1)	18
Total Number of consumers go to movie	17
Total number of consumers waiting outside or cancel	49

The second scenario added cashiers to 2 people, the results could be seen in table 2. In the table could be seen that the number of people queuing has decreased from the 19 to 18 people. As for cashier utility, cashier 1 still had utility 1, while cashier 2 had 0.99 utility. It indicated that cashier 1 had no idle time, while for cashier 2 there was very little idle time. The changing occurred in waiting times, and people who did not enter the cinema were reduced, while the number of people who were served by cashiers increased.

Table 2. Results of simulation with 2 servers

Description	Value
Number of waiting (Average) Total	18
Average of Waiting Time (minutes)	32,72
utilization of cashier 1	1
utilization of cashier 2	0,99
Total Number Seized (Cashier 1)	18
Total Number Seized (Cashier 2)	17
Total Number of consumers go to movie	34
Total number of consumers waiting outside or cancel	21

The third scenario, the cashier increases by 3 people. From the results (table 3) it could be seen that the total waiting time was reduced to 12, while the waiting time was to 18.56. For the output of the utilization of one cashier was 1 while the other two cashiers were 0.98. Meanwhile, the total people served also increased to 50 people. From the results described above, the addition of a cashier changed the others.

Table 3. Results of simulation with 3 servers

Description	Value
Number of waiting (Average) Total	12
Average of Waiting Time (minutes)	18,56
utilization of cashier 1	1
utilization of cashier 2	0,9884
utilization of cashier 3	0,9756
Total Number Seized (Cashier 1)	17
Total Number Seized (Cashier 2)	18
Total Number Seized (Cashier 3)	18
Total Number of consumers go to movie	50
Total number of consumers waiting outside or cancel	0

In the fourth scenario, the number of cashiers increased by four. According to the results (table 4), the total waiting time was reduced to 4, while the waiting time was reduced to 6.49. For the utilization output, each cashier was less than 1 but greater than 0.95. Meanwhile, the total number of people served increased to 64.

Table 4. Results of simulation with 4 servers

Description	Value
Number of waiting (Average) Total	4
Average of Waiting Time (minutes)	6.49
utilization of cashier 1	0.9942
utilization of cashier 2	0.972
utilization of cashier 3	0.9621
utilization of cashier 4	0.9524
Total Number Seized (Cashier 1)	17
Total Number Seized (Cashier 2)	16
Total Number Seized (Cashier 3)	18
Total Number Seized (Cashier 4)	17
Total Number of consumers go to movie	64
Total number of consumers waiting outside or cancel	0

In the fifth Scenario, the number of cashiers were increased to 1 people. From the results (table 5) it can be seen that the total waiting time was reduced to 4, while the waiting time was reduced to 0.93. For the utilization of the output of all cashiers were between 0.83 and 0.96 Meanwhile, the total people served also increased to 75 people.

Table 5. Results of simulation with 5 servers

Description	Value
Number of waiting (Average) Total	1

Average of Waiting Time (minutes)	0.93
utilization of cashier 1	0.96
utilization of cashier 2	0.91
utilization of cashier 3	0.88
utilization of cashier 4	0.83
utilization of cashier 5	0.83
Total Number Seized (Cashier 1)	17
Total Number Seized (Cashier 2)	18
Total Number Seized (Cashier 3)	15
Total Number Seized (Cashier 4)	15
Total Number Seized (Cashier 5)	15
Total Number of consumers go to movie	75
Total number of consumers waiting outside or cancel	0

In the sixth scenario, the number of queues that did not change, it was 1, as well as the number served and those who could not watch, namely 75 people and 0 people. while the waiting time was 0.18 and the cashier utility was in the range of 0.43 and 0.92. If it was assumed that the idle time was 5%, then this scenario has succeeded in achieving this goal.

Table 6. Results of simulation with 6 servers

Description	Value
Number of waiting (Average) Total	1
Average of Waiting Time (minutes)	0.18
utilization of cashier 1	0.92
utilization of cashier 2	0.82
utilization of cashier 3	0.81
utilization of cashier 4	0.77
utilization of cashier 5	0.69
utilization of cashier 6	0.43
Total Number Seized (Cashier 1)	15
Total Number Seized (Cashier 2)	15
Total Number Seized (Cashier 3)	14
Total Number Seized (Cashier 4)	14
Total Number Seized (Cashier 5)	14
Total Number Seized (Cashier 6)	9
Total Number of consumers go to movie	75
Total number of consumers waiting outside or cancel	0

Based on the evaluation of six alternative simulation scenarios (Table 1-6), scenario 6 was determined to be the most desirable by including six cashiers. This study has limitations, including the need for several scenarios to determine which one is the best. The simulation technique is useful for testing policies with predetermined parameters. These optimal parameters can be obtained by optimization techniques. so that further research can use a combination of optimization and simulation methods.

4. CONCLUSION

In this study, a queuing system model was proposed by considering the queuing limitations caused by COVID-19. Several scenarios of changes to the proposed design of the queuing system model (addition of cashiers) were tested using the simulation method and obtained different results for each scenario. From the simulation results of 6 scenarios, the best scenario was obtained by considering the queue, the customers served and the cashier's utility. As a result, the scenario by placing 6 cashiers was the best selection.

ACKNOWLEDGMENT

Thank you to the respondents and those who assisted with the data collection for this study.

REFERENCES

- [1] B. K. Choi and D. Kang, *Modeling and simulation of discrete event systems*. John Wiley & Sons, 2013.
- [2] D. S. N, D. S. Utomo, and W. Tambunan, "Analisis sistem antrian pelayanan teller bank pada aktivitas nasabah dengan menggunakan simulasi (studi kasus Bank "XYZ")," *ReTII*, 2017, [Online]. Available: [//journal.itny.ac.id/index.php/ReTII/article/view/344](http://journal.itny.ac.id/index.php/ReTII/article/view/344)
- [3] A. Alban *et al.*, "ICU capacity management during the COVID-19 pandemic using a process simulation," *Intensive Care Med.*, vol. 46, no. 8, pp. 1624–1626, 2020, doi: 10.1007/s00134-020-06066-7.
- [4] A. Asgary, M. M. Najafabadi, R. Karsseboom, and J. Wu, "A drive-through simulation tool for mass vaccination during covid-19 pandemic," in *Healthcare (Switzerland)*, 2020, vol. 8, no. 4, p. 469. doi: 10.3390/healthcare8040469.
- [5] L. R. De Groot and A. Hubl, "Developing a Calibrated Discrete Event Simulation Model of Shops of a Dutch Phone and Subscription Retailer during COVID-19 to Evaluate Shift Plans to Reduce Waiting Times," in *Proceedings - Winter Simulation Conference*, 2021, vol. 2021-December, pp. 1–12. doi: 10.1109/WSC52266.2021.9715306.
- [6] M. Saidani, H. Kim, and J. Kim, "Designing optimal COVID-19 testing stations locally: A discrete event simulation model applied on a university campus," *PLoS One*, vol. 16, no. 6 June, p. e0253869, 2021, doi: 10.1371/journal.pone.0253869.
- [7] S. L. Zimmerman, A. R. Rutherford, A. van der Waall, M. Norena, and P. Dodek, "A Queuing Model for Ventilator Capacity Management during the COVID-19 Pandemic," *medRxiv*, p. 2021.03.17.21253488, 2022, [Online]. Available: <http://medrxiv.org/content/early/2022/02/16/2021.03.17.21253488.abstract>
- [8] M. R. Galankashi, E. Fallahiarezoudar, A. Moazzami, N. M. Yusof, and S. A. Helmi, "Performance evaluation of a petrol station queuing system: A simulation-based design of experiments study," *Adv. Eng. Softw.*, vol. 92, pp. 15–26, 2016, doi: 10.1016/j.advengsoft.2015.10.004.
- [9] I. A. Hasugian, Fernando, and Supriadi, "Simulation of Queuing System for Customer Service Improvement: A Case Study," in *IOP Conference Series: Materials Science and Engineering*, 2020, vol. 851, no. 1, p. 40020. doi: 10.1088/1757-899X/851/1/012030.
- [10] T. Antczak, R. Weron, and J. Zabawa, "Data-driven simulation modeling of the checkout process in supermarkets: Insights for decision support in retail operations," *IEEE Access*, vol. 8, pp. 228841–228852, 2020, doi: 10.1109/ACCESS.2020.3045919.
- [11] J. V. Pereira Junior, A. M. da Silva, and D. G. de Moraes, "Discrete simulation applied to queue management in a supermarket," *Indep. J. Manag. Prod.*, vol. 11, no. 5, p. 1667, 2020, doi: 10.14807/ijmp.v11i5.1296.
- [12] H. Kaid, A. Dabwan, and A. Al-Ahmari, "Modeling and simulation of queuing systems using stochastic Petri net and Arena software: A case study," in *Proceedings of the International Conference on Industrial Engineering and Operations Management*, 2018, vol. 2018-March, pp. 1303–1315.
- [13] A. Kambli, A. A. Sinha, and S. Srinivas, "Improving campus dining operations using capacity and queue management: A simulation-based case study," *J. Hosp. Tour. Manag.*, vol. 43, pp. 62–70, 2020, doi: 10.1016/j.jhtm.2020.02.008.
- [14] S. Robinson, *Simulation: the practice of model development and use*. Bloomsbury Publishing, 2014.
- [15] W. D. Kelton, *Simulation with ARENA*. McGraw-hill, 2002.

International Conference on Sustainable Engineering and Technology [IC-SET] 2022 - Important Notes External Inbox x

Jun 3, 2022, 4:21 PM ☆ ↶ ⋮

 **Fakultas Teknik** <ft@ustjogja.ac.id>
to me

Dear Author(s)

Firstly, we would like to thank you for your enthusiasm in participating in this International Conference on Sustainable Engineering and Technology (IC-SET **UST**) 2022. This event is organized by the Faculty of Engineering Universitas Sarjanawiyata Tamansiswa Indonesia. Through this mail, we are pleased to inform you that your abstract has been accepted to oral presentation. Please, pay attention to some important notes below:

1. The parallel presentation will be held on June 7th, starting from 01.15 pm (GMT+7) to 03.00 pm through zoom meeting (virtual).
2. Due to limited presentation time and room distribution, we will further select the presenters that should deliver the presentation on the conference day through live streaming presentation (no video presentation) on zoom. The detailed information will be described in the program book which will be sent two days before the event.
3. For all presenters (regardless the point no. 2 above), please make a 10-minute presentation video and share the link to this email ft@ustjogja.ac.id by Sunday, June 5th, 2022 using this format:
Subject: [IC-SET **UST** 2022] _VIDEO_ write the last name of the first/corresponding author

On body mail, please indicate
Author(s):
Affiliation:
Title of the article:
Video Link:

Before, you may upload your presentation video on Youtube/cloud storage (such as Dropbox or Google Drive)/other platforms and please make sure that the video link is downloadable.

4. We also invite you to join our Whatsapp Group by clicking the following link. Otherwise, for those who cannot connect to the application, we are still going to send any information via email.
<https://chat.whatsapp.com/C1zP930W1tqFnz7WV66b>

Congratulations and we are looking forward to meeting you at the conference virtually. Should you have any further inquiry please contact us via email at ft@ustjogja.ac.id or phone (+62 812-3112-6116).

Sincerely,
Organizing Committee

----- UNIVERSITAS SARJANAWIYATA TAMANSISWA -----
Fakultas Teknik UST
Jl. Mitan No. 15 Yogyakarta
<http://ft.ustjogja.ac.id>
(0271) 501.7929



UNIVERSITAS WIDYA MATARAM

FAKULTAS SAINS DAN TEKNOLOGI

Dalem Mangkubumen KT III/237 Telp (0274) 377150 Yogyakarta 55132

SURAT TUGAS

No:202/D/FST-UWM/IX/2021

Yang bertanda tangan di bawah ini, Dekan Fakultas Sains dan Teknologi Universitas Widya Mataram, menugaskan kepada seluruh Dosen FST-UWM yang tersebut di bawah ini,

Nama :

1. Ir. Tri Yuniastuti, MT.
2. Ir. Puji Asih, M.Si.
3. Ir. Ilmardani Rince Ramli, MM.
4. Ir. Suhartono, MT.
5. Drs. Jono, MT.
6. Siti Lestariningsih, ST., M.Sc.
7. Masrul Indrayana, ST., MT.
8. Iva Mindhayani, ST., MT.
9. Dr. Ir. Siti Nur Purwandhani, MP.
10. Ir. Kuntjahjwati SAR, MP.
11. Prof. Dr. Ir. Ambar Rukmini, MP.
12. Eman Darmawan, STP, MP.
13. Dyah Titin Laswati, STP, MP.
14. Masrukan, S. TP., M.Sc.
15. Dr. Satrio Hasto Broto Wibowo, ST., M.Sc.
16. Nurina Vidya Ayuningtyas, ST., M.Sc. IAI.
17. Padmana Grady Prabasmara, ST., M.Sc. IAI
18. Desy Ayu Krisna Murti, ST., M.Sc.
19. Ir. YE. Suharno, MT. IAI.
20. Istiana Adianti, ST., M.Sc. IAI
21. Bayu Dwi Wismantoro, ST., M.Eng.

Untuk melaksanakan kegiatan **Penelitian/membuat karya ilmiah** yang sesuai dengan bidang masing-masing, pada Semester Gasal Tahun Akademik 2021/2022.

Demikian surat tugas ini dibuat untuk dapat dilaksanakan sebagaimana mestinya.

Yogyakarta, 10 September 2021

Dekan,



Prof. Dr. Ir. Ambar Rukmini, M.P.
NIP : 196412081992032001